



Roots Type Rotary Blower
DSR Series



Contents

Description	1
Features	1
Applications	2
Functioning Principle	2
How To Use Performance Tables	3
Specifications	4
Sectional Drawing	5
Performance Table (Belt & Pulley)	6 - 7
Noise Level	8
Reference Piping Installation Drawing	9
Outline Dimensions (Belt & Pulley)	10
Accessories	11

Description

MIZU roots type rotary blower DSR Series has been developed by adopting innovated techniques, based on the manufacturing experience in the roots type rotary blower since 1980.

These blowers have improved full-adiabatic efficiency as well as volumetric efficiency and provide superior air capacity vs pressure characteristic.

The excellence of efficiency leads and double to reduction of the heat from the blower itself, and therefore reduction of the temperature elevation and thus the operation of blower in dry condition has become practical at the discharge pressure as low as 0.6 kgf/cm²

Features

- The helical construction uses the stator helical, method the screen lines of casing at the suction and discharge sides are cut to a helical shape and the triangle suction and discharge port formed by a straight line of the rotor top is to be opened and closed gradually.
Therefore, the suction and discharge ports of this type is not opened or closed at moments, which makes these blowers have an only limited operation sound and almost free from pulsations from discharge.
- The rotors are three-lobe straight type, so that the rotors can not interfere with each other, resulting from minor displacements in the thrust direction as in the helical type. Therefore, the clearance between the rotors should be assured in the profile direction only and thus there is no necessity of an excessive on account of displacements in the thrust direction as in case of the rotor helical type. From such reasons, these blowers have a very high efficiency Mizu blower also double tank oil lubrication.
- By adoption of an unique profile of rotor, the clearance between the rotors can be held to be constant which makes the efficiency even higher.
- The precision of rotors is fully controlled and variation of precision between blowers is almost nil because the rotors are produced under the mass production control by utilizing a precision NC machine. In addition, the rotors are dynamically balanced in the fabrication stage already, so that these rotors are almost free from vibrations as in the case of conventional rotors which are still unbalanced.

Applications

MIZU roots type rotary blower DSR Series can be apply for:

- Fish care
- Back washing
- Foaming in bath
- Transport of particles
- Wastewater aeration for shops and livestock industries
- Stirring in plated vessel
- Vacuum pack for foods
- Combustion a fireplace
- Wastewater aeration in condominiums

Functioning principle

The conventional roots type rotary blowers, either two-lobe or three-lobe, have the same compression occurs upon reverse-flowing of high pressure air instantly when the rotor end is opened in line with the discharge opening. Such reverse flow and a rapid change in the compression as involved in the above compression is the cause of noise

The Helical construction of these blowers was designed to eliminate such noise, the feature of which will be described as follows.

Three-lobe Roots Blower Functioning Principle Flow

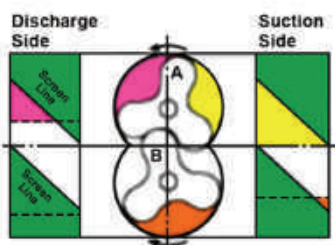
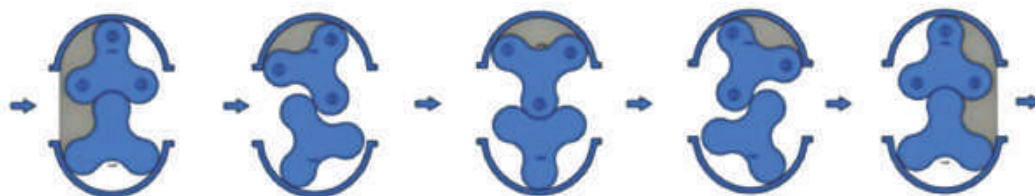

Rotor A: The suction side is open over full length thereof, and is about to close gradually while the discharge side is open half-way by opening gradually

Rotor B: The suction side is almost fully closed by closing gradually while the discharge side is not yet opened but is about to open

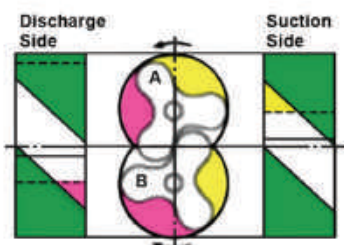

Rotor A: The suction side is little more closed, where the shaded triangle port is going smaller gradually along with the screen line of casing while discharge has already been completed at the discharge side.

Rotor B: The suction side is immediately before going on to the screen line of casing while the discharge side is under the discharge process, where the triangle port is opening gradually.

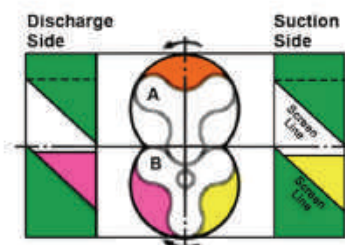

Rotor A: Both of the suction and discharge sides are closed and immediately before opening at the discharge side.

Rotor B: The closing process has just been set out and is now closing gradually while the discharge side is immediately before full opening by opening gradually.

The Shaded portions show openings of suction and discharge ports.

How to Use Performance Tables

The performance tables give the model number, bore, r.p.m., discharge pressure, air capacity and required power of the blower.

- The air capacity in the tables is indicated in the standard suction state. The standard suction state here in mentioned is defined as the condition at 20°C temperature, 1.0332kgf/cm² (101.3kPa) absolute pressure and 65% relative humidity.
- The reference air capacity [0°C temperature and 1.0332kgf/cm² (101.3kPa) absolute pressure] is generally indicated in Nm³/min. However, it may be converted into the standard air capacity by the following equation, if the suction pressure is equal.

$$Q_s = Q_n \times 1.0732$$

where, Q_s: standard air capacity and Q_n: reference air capacity.

- The discharge air capacity can be converted into the standard air capacity by the following equation.

$$Q_s = Q_d \times \frac{1.0332 + P_d}{1.0332} \times \frac{273 + t_s}{273 + t_d}$$

Where, Q_d : discharge air capacity, in m³/min

P_d : discharge pressure, in kgf/cm²

t_s : suction temperature, in °C

t_d : discharge temperature, in °C

- According to the air capacity and discharge pressure as calculated above, the model number, bore, r.p.m and required power can be found in the performance table.
- The motor powers are indicated by color marking and the motor powers to be used should be that indicated.
- The choice is overlapped depending upon the type of blower. For reference, however, selection should be lower number blowers for the economy and higher number blowers for the sound level.
- power (output) can calculated using the formula

$$kW = \sqrt{3} \times V \times A \times \cos \theta \times \text{Eff.} \times 1010$$

V : voltage A : Current Cos θ: motor power facto

Eff : motor efficiency

pressure	atm	kpa	mbar	lbf/m ² (psi)	kgf/cm ²	in HG	ft Aq	mmHg (Torr)	mmAq
1 atm	1	101.325	1013.25.	14.698	1.0333	29.921	33.914	760	1033
1 kpa	0.0099	1	10	0.145	0.0102	0.295	0.335	7.5	103
1 mbar	0.009	0.1	1	0.0145	0.00102	0.0295	0.0335	0.75	10.198
1 lbf/m ² (psi)	0.069	6.894	68.965	1	0.0703	2.036	2.308	51.71	703
1 kgf/cm ²	0.968	98.062	980.392	14.228	1	28.96	32.82	735.53	10000
1 inHg	0.0334	3.3863	33.898	0.491	0.0345	1	1.133	25.4	345.3
1 ftAq	0.02295	2.99	29.851	0.434	0.0305	0.882	1	22.42	304.8
1 mmHg(Torr)	0.013	0.1338	1.333	0.019	0.0014	0.04	0.045	1	13.6
1 mmaq	0.000097	0.0098	0.09803	0.001	0.003	0.003	0.003	0.074	1

CAPACITY	m ³ /min	l/min	cm ³ /sec	in ³ /sec	ft ³ /min(CFM)	U.S GPM
1m ³ /min	1	1000	1667	1016	35.288	264.172
1l/min	0.001	0	16.67	1.02	0.0353	0.2641
1cm ³ /sec	0.00006	0.06	1	0.061	0.002	0.0158
1in ³ /sec	0.00098	0.983	16.39	1	0.035	0.2589
1ft ³ /min(CFM)	0.028	28.32	471.957	28.8	1	7.4838
1U.S. GPM	0.003785	3.4785	63.0915	3.8460	0.13360	1

Pressure Conversion Formula

1 kpa = 1000 pa = 1000 N/M²

1 bar = 1000 mbar = 100 kpa

1 mbar = 100 M/M²

Specifications



- **Major Specifications of Type DSR**

Bore	: 50 to 320A
Air Capacity	: 0.7 to 185 m ³ /min
Pressure	: 0.1 to 0.6 kgf/cm ²
Motor Power	: 1.1 - 250 kW

- **Major Specifications of Type DSR - HB**

Bore	: 50 to 320 HB
Air Capacity	: 0.5 to 180 m ³ /min
Pressure	: 0.1 to 1 kgf/cm ²
Motor Power	: 3 - 400 kW

Standard Accessories

- Common Base
- V-Belt Cover & V-Belt
- Blower Pulley, Motor Pulley (if motor included)
- Suction Silencer (With Air Filter)
- Safety Valve
- Pressure Gauge
- Discharge silencer (JIS 10k)

1. The performance tables and standardized specifications are made available for all types to allow easy selection of one in need.
2. The blowers including accessories and nachi bearing are standardized under the mass production control so as to be able to correspond to the orders and needs at any time.
3. The operation noise is lowered to the level not ever achieved by adopting, in addition to the helical construction, a silent air cleaner as appropriate to each type of the blowers.
4. The rotor is a precision product machined in its full surface and since it is dynamically balanced in the shop completely, it will have almost no vibration.
5. The blowers require only a small area for installation due to a compact design.

Sectional Drawing

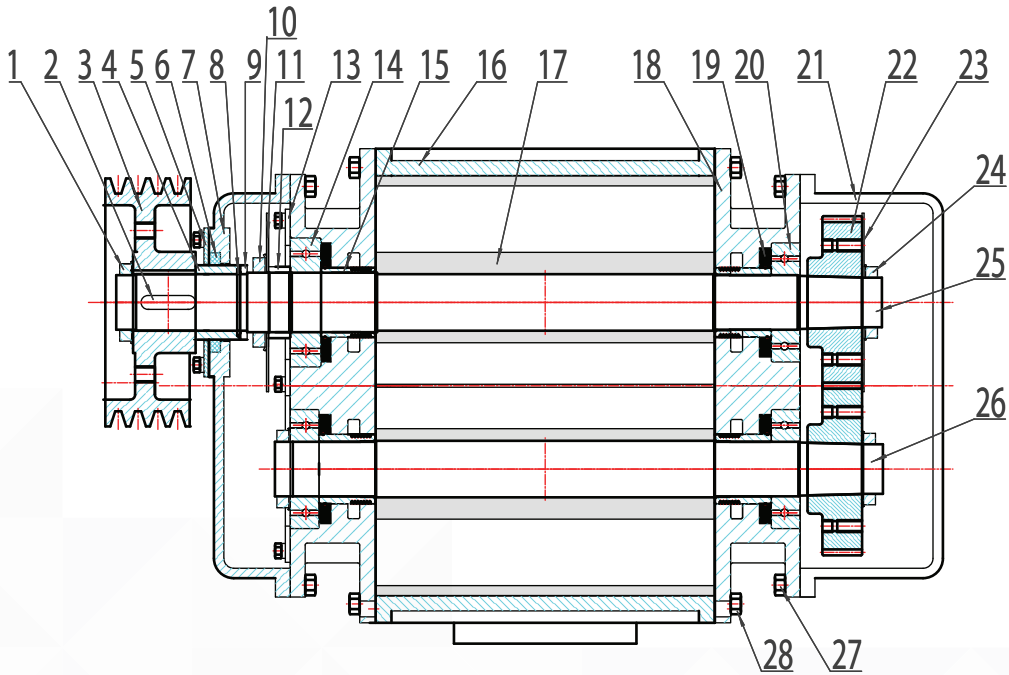

No	Description	No	Description	No	Description
1	Round Nut	11	Oil Splash	21	Nut
2	Lock Key	12	Spacer Ring	22	Oil Splash
3	Pulley	13	Bearing Cover	23	Oil Splash
4	Shaft Sleeve	14	Bearing	24	Nut
5	Press Cover	15	Seal Cartridge	25	Driving Shaft
6	Oil Seal	16	Case	26	Driving Shaft
7	Oil Tank	17	Impeller	27	Bolt
8	O Ring	18	Side Plate	28	Bolt
9	Gasket	19	Oil Baffle		
10	Nut	20	Bearing		

PERFORMANCE TABLE (BELT & PULLEY)

Pressure Performance Table

Qs = Inlet air flow (m³/min)

La = Blower shaft power (Kw)

		Pressure																							
Model	Bore	Mmaq	1000		1500		2000		2500		3000		3500		4000		4500		5000		5500		6000		
		KPA	9.8		14.7		19.6		24.5		29.4		34.3		39.2		44.1		49		53.9		58.8		
		Rpm	Qs	La	Qs	La	Qs	La	Qs	La	Qs	La	Qs	La	Qs	La	Qs	La	Qs	La	Qs	La	Qs	La	
DSR 50	50A	1100	1.22	0.30	1.14	0.41	1.12	0.52	1.03	0.67	0.99	0.78	0.92	0.91	0.90	1.04	0.83	1.16	0.78	1.32	0.70	1.54	0.67	1.60	
		1240	1.38	0.38	1.30	0.50	1.27	0.64	1.18	0.79	1.14	0.92	1.07	1.05	1.05	1.20	0.98	1.37	0.94	1.49	0.88	1.65	0.84	1.78	
		1350	1.53	0.44	1.45	0.61	1.42	0.74	1.32	0.85	1.28	1.04	1.25	1.17	1.19	1.34	1.15	1.53	1.09	1.65	1.03	1.80	0.99	1.95	
		1450	1.66	0.50	1.55	0.64	1.54	0.82	1.43	0.96	1.40	1.14	1.34	1.30	1.30	1.47	1.21	1.63	1.20	1.79	1.12	1.91	1.14	2.15	
		1530	1.75	0.56	1.66	0.75	1.63	0.90	1.53	1.07	1.49	1.24	1.45	1.41	1.39	1.58	1.33	1.74	1.30	1.92	1.28	2.12	1.24	2.29	
		1640	1.89	0.64	1.79	0.81	1.76	1.01	1.71	1.15	1.62	1.37	1.67	1.54	1.55	1.74	1.50	1.88	1.43	2.10	1.40	2.28	1.38	2.49	
		1830	2.00	0.71	1.91	0.95	1.87	1.10	1.82	1.25	1.73	1.48	1.79	1.68	1.62	1.86	1.70	2.03	1.53	2.25	1.64	2.47	1.48	2.66	
		1840	2.13	0.80	2.11	1.03	2.00	1.20	1.99	1.39	1.86	1.62	1.92	1.79	1.75	2.02	1.83	2.25	1.67	2.43	1.77	2.65	1.62	2.86	
DSR 65	65A	1140	1.67	0.38	1.55	0.63	1.48	0.80	1.42	1.02	1.32	1.16	1.23	1.37	1.18	1.52	1.14	1.74	1.07	1.82	0.99	2.02	0.95	2.16	
		1240	1.92	0.48	1.84	0.72	1.73	0.92	1.63	1.14	1.58	1.33	1.52	1.55	1.44	1.74	1.35	1.94	1.32	2.10	1.25	2.32	1.21	2.48	
		1360	2.16	0.56	2.08	0.83	1.98	1.04	1.5	1.26	1.82	1.48	1.77	1.73	1.68	1.94	1.64	2.20	1.56	2.35	1.51	2.55	1.42	2.72	
		1450	2.31	0.63	2.24	0.85	2.14	1.12	2.05	1.36	2.00	1.60	1.95	1.83	1.86	2.10	1.82	2.34	1.74	2.54	1.70	2.75	1.63	3.00	
		1530	2.45	0.70	2.35	0.98	2.28	1.20	2.23	1.47	2.14	1.72	2.09	1.95	2.02	2.25	1.97	2.52	1.90	2.72	1.86	2.95	1.79	3.20	
		1640	2.66	0.80	2.59	1.05	2.49	1.33	2.44	1.62	2.36	1.89	2.32	2.15	2.24	2.41	2.20	2.75	2.12	2.95	2.08	3.24	2.01	3.46	
		1740	2.86	0.89	2.93	1.20	2.69	1.46	2.64	1.76	2.56	2.04	2.53	2.32	2.44	2.64	2.41	2.96	2.32	3.16	2.28	3.47	2.21	3.70	
		1820	3.02	0.96	3.01	1.25	2.85	1.56	2.83	1.88	2.72	2.16	2.68	2.44	2.60	2.79	2.56	3.12	2.48	3.33	2.44	3.65	2.37	3.90	
DSR 80	80A	1140	3.09	1.04	3.02	1.34	2.90	1.60	2.82	1.95	2.78	2.14	2.68	2.45	2.63	2.69	2.52	3.02	2.48	3.22	2.38	3.45	2.36	3.74	
		1230	3.37	1.14	3.25	1.44	3.18	1.76	3.08	2.04	3.06	2.35	2.95	2.63	2.91	2.94	2.80	3.25	2.76	3.53	2.65	3.83	2.63	4.11	
		1300	2.59	1.22	3.52	1.55	3.41	1.89	3.35	2.23	3.27	2.51	3.22	2.85	3.12	3.14	3.05	3.47	2.97	3.77	2.92	4.07	2.84	4.41	
		1360	3.77	1.29	3.99	1.65	3.59	1.99	3.82	2.35	3.46	2.64	3.69	2.97	3.30	3.31	3.53	3.65	3.16	3.98	3.40	4.32	3.02	4.65	
		1460	4.08	1.40	4.00	1.80	3.90	2.17	3.88	2.53	3.76	2.87	3.72	3.22	3.62	3.60	3.56	3.91	3.46	4.32	3.42	4.65	3.34	5.06	
		1560	4.38	1.52	4.19	1.95	4.10	2.32	4.03	2.76	4.00	3.10	3.98	3.46	3.93	3.88	3.88	4.41	3.77	4.66	3.70	5.25	3.65	5.48	
		1650	4.66	1.62	4.55	2.13	4.48	2.50	4.42	2.94	4.36	3.31	4.22	3.75	4.16	4.14	4.10	4.74	4.05	4.98	4.00	5.62	3.92	5.85	
		1730	4.90	1.71	4.80	2.25	4.73	2.64	4.69	3.05	4.60	3.50	4.54	3.94	4.46	4.36	4.42	4.82	4.30	5.26	4.26	5.72	4.18	6.18	
1820	5.18	1.81	5.12	2.35	5.00	2.80	4.96	3.25	4.88	3.70	4.80	4.13	4.74	4.62	4.65	5.06	4.58	5.57	4.50	6.04	4.45	6.56			
DSR 100	100A	1060	4.57	1.35	4.42	1.83	4.27	2.31	4.07	2.72	3.95	3.10	3.84	3.55	3.70	3.97	3.57	4.46	3.48	4.95	3.35	5.42	3.28	5.86	
		1140	4.97	1.57	4.82	2.03	4.65	2.46	4.52	2.94	4.36	3.41	4.25	3.93	4.12	4.38	4.03	4.86	3.90	5.38	3.83	5.85	3.71	6.38	
		1220	5.37	1.68	5.15	2.22	5.03	2.70	4.87	3.23	4.76	3.71	4.63	4.22	4.53	4.76	4.44	5.27	4.32	5.76	4.25	6.35	4.13	6.90	
		1310	5.73	1.87	5.60	2.43	5.44	2.96	5.34	3.52	5.18	4.05	5.05	4.63	4.95	5.18	4.86	5.77	4.74	6.30	4.66	6.95	4.55	7.48	
		1460	6.53	2.18	6.35	2.75	6.25	3.40	6.13	3.95	6.00	4.62	5.87	5.22	5.78	5.87	5.66	6.54	5.58	7.10	5.45	7.76	5.39	8.45	
		1560	6.91	2.40	6.79	3.04	6.64	3.67	6.55	4.32	6.40	4.98	6.30	5.65	6.19	6.30	6.07	6.97	5.99	7.61	5.89	8.35	5.81	9.00	
		1680	7.63	2.78	7.47	3.45	7.36	4.18	7.26	4.92	7.13	5.62	7.04	6.33	6.92	7.08	6.84	7.85	6.73	8.50	6.65	9.32	6.55	10.03	
		1780	8.09	3.05	7.94	3.83	7.84	4.56	7.75	5.35	7.62	6.10	7.54	6.84	7.42	7.63	7.34	8.45	7.23	9.15	7.16	9.95	7.06	10.71	
1880	8.57	3.33	8.43	4.15	8.36	4.93	8.23	5.77	8.15	6.55	8.03	7.35	7.95	8.18	7.88	9.03	7.77	9.80	7.65	10.64	7.60	11.42			
DSR 125	125A	980	6.50	1.65	6.32	2.25	6.15	2.80	6.03	3.42	5.95	4.10	5.80	4.73	5.75	5.40	5.62	6.13	5.55	5.70	5.45	7.22	5.37	8.05	
		1050	6.95	1.90	6.75	2.53	6.63	3.15	6.52	3.83	6.42	4.53	6.32	5.22	6.22	5.95	6.13	6.63	6.03	7.30	5.93	7.93	5.85	8.75	
		1200	8.00	2.50	7.82	3.22	7.65	3.92	7.53	4.72	7.45	5.50	7.32	6.25	7.25	7.10	7.12	7.92	7.00	8.65	6.95	9.43	6.90	10.25	
		1300	8.75	2.90	8.53	3.63	8.40	4.50	8.25	5.33	8.19	6.20	8.07	7.03	8.00	7.90	7.93	8.83	7.82	8.65	7.76	10.03	7.64	11.40	
		1390	9.30	3.20	9.12	4.02	8.95	4.90	8.85	5.82	8.74	6.70	8.65	7.62	8.54	8.50	8.42	9.42	8.37	10.35	8.25	11.27	8.20	12.20	
		1450	9.72	3.45	9.48	4.23	9.35	5.20	9.23	6.13	9.15	7.10	9.03	8.03	8.95	9.00	8.82	9.93	8.77	10.90	8.73	11.82	8.60	12.80	
		1530	10.27	3.80	10.09	4.72	9.90	5.65	9.82	6.63	9.70	7.65	9.62	8.62	9.50	9.60	9.43	10.62	9.33	11.60	9.23	12.63	9.15	13.60	
		1630	10.96	4.30	10.73	5.23	10.57	6.25	10.45	7.23	10.37	8.35	10.25	9.33	10.17	10.35	10.08	11.33	10.01	12.40	9.95	13.53	9.85	14.60	
1750	11.78	4.90	11.52	5.82	11.38	6.95	11.27	7.93	11.18	9.18	11.07	10.22	10.99	11.26	10.93	12.35	10.83	13.38	10.73	14.72	10.66	15.80			

● Please contact us for outline dimension and installation drawing, performance curve and noise curve.



Performa Table (Belt & Pulley)

Pressure Performance Table

Qs = Inlet air flow (m³/min)

La = Blower shaft power (kW)

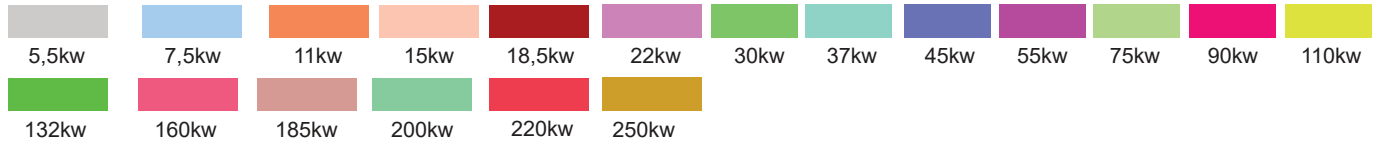

Type	Bore	Pressure																								
		mmAq	1000		1500		2000		2500		3000		3500		4000		4500		5000		5500		6000			
		kpa	Qs	La	Qs	La	Qs	La	Qs	La	Qs	La	Qs	La	Qs	La	Qs	La	Qs	La	Qs	La	Qs	La		
DSR150	150A	810	12.01	3.85	11.74	5.03	11.54	6.20	11.33	7.32	11.15	8.50	11.02	9.62	10.86	10.80	10.74	11.97	10.65	13.20	10.45	14.42	10.39	15.60		
		860	12.80	4.40	12.64	5.63	12.40	6.86	12.23	8.03	12.03	9.30	11.84	10.47	11.75	11.70	11.63	13.03	11.54	14.25	11.42	15.53	11.27	16.80		
		970	14.70	5.58	14.52	7.02	14.30	8.30	14.13	9.63	13.95	11.05	13.82	12.43	13.70	13.80	13.62	15.23	13.50	16.60	13.33	18.03	13.23	19.40		
		1110	17.08	7.00	16.92	8.62	16.70	10.15	16.54	11.72	16.37	13.10	16.23	14.84	16.15	16.50	16.07	18.03	15.95	19.60	15.82	21.23	15.70	22.80		
		1180	18.25	7.80	18.13	9.43	17.92	11.10	17.75	12.73	17.59	14.40	17.46	16.03	17.37	17.80	17.25	19.42	17.17	21.10	17.05	22.82	16.97	24.40		
		1240	19.27	8.45	19.12	10.21	18.95	11.90	18.75	13.62	18.63	15.40	18.55	17.05	18.43	18.90	18.35	20.72	17.23	22.40	18.15	24.23	16.03	25.80		
		1400	22.00	10.20	21.85	12.12	21.70	14.00	21.53	15.93	21.40	17.90	21.32	19.92	21.20	21.90	21.15	23.83	21.05	25.80	20.95	27.93	20.87	29.70		
		1450	22.85	10.70	22.70	12.75	22.58	14.68	22.45	16.68	22.33	18.70	22.23	20.80	22.12	22.90	22.01	24.85	21.92	26.88	21.83	29.00	21.74	30.90		
		1520	23.93	11.65	23.84	13.38	23.68	15.90	23.52	17.43	23.40	20.15	22.56	21.59	23.21	24.60	23.13	25.84	23.04	28.90	22.95	30.20	22.82	33.30		
		1620	25.42	13.40	25.32	15.62	25.15	18.00	25.02	20.42	24.86	22.60	24.74	25.03	24.68	27.40	24.55	29.63	24.48	32.05	24.32	34.42	24.27	36.90		
1730	27.05	15.30	26.94	17.63	26.77	20.20	26.63	22.92	26.48	25.30	26.33	27.92	26.27	30.40	26.15	33.02	26.08	35.55	25.95	38.02	25.87	40.89				
DSR175	150A	970	22.73	7.90	22.20	10.19	22.13	11.25	21.63	13.35	21.05	15.46	20.85	17.57	20.53	19.65	20.21	21.75	20.12	23.87	19.83	26.03	19.65	28.14		
		1110	26.75	12.21	26.54	11.94	26.33	13.14	25.83	15.53	25.50	17.93	25.24	20.33	24.83	22.73	24.55	25.10	24.23	27.53	24.07	29.93	23.95	32.33		
		1180	28.65	13.23	28.50	12.54	28.35	13.84	27.96	16.35	27.55	18.95	27.17	21.47	26.83	24.07	26.57	26.63	26.34	29.15	26.15	31.74	25.95	34.26		
		1240	30.25	12.65	30.10	13.43	29.94	14.75	29.53	17.47	29.15	28.16	28.85	22.58	28.55	25.54	28.27	28.24	28.05	30.93	27.84	33.65	27.63	36.26		
		1400	34.22	16.75	33.93	16.70	33.65	18.54	33.35	21.65	33.26	25.54	32.83	27.57	32.55	30.64	32.33	38.63	32.03	36.65	31.82	39.71	31.62	42.76		
		1460	35.26	17.47	35.10	17.25	35.04	19.09	34.69	22.45	34.50	25.79	34.09	28.55	33.86	31.74	33.64	34.85	33.34	38.01	33.18	41.68	32.94	44.36		
		1520	35.65	17.51	36.54	17.80	36.43	19.64	36.03	22.94	35.73	26.23	35.35	29.52	35.17	32.83	34.95	36.07	34.65	39.37	34.52	43.65	34.25	45.95		
1620	38.67	18.72	38.52	21.13	38.36	22.86	38.03	26.43	37.84	29.94	37.43	39.42	37.15	36.96	36.96	40.43	36.65	43.95	36.55	47.75	36.35	50.97				
DSR200	200A	810	31.17	11.26	30.81	12.94	30.54	14.63	29.95	17.62	29.52	20.66	29.23	23.85	28.87	26.96	28.55	29.97	28.24	33.14	27.93	36.07	27.65	39.07		
		900	35.01	13.41	34.71	15.27	34.41	17.12	34.01	20.42	33.62	24.22	33.34	27.55	33.03	30.95	32.75	34.42	32.36	37.85	32.05	41.04	31.73	44.35		
		980	35.52	15.52	38.42	17.42	38.10	19.31	37.62	22.91	37.31	27.15	37.07	30.76	36.75	34.53	36.44	38.25	36.05	42.04	35.66	45.55	35.25	49.35		
		1070	42.53	17.81	42.29	19.52	42.03	21.22	41.63	25.82	41.33	30.12	41.11	34.45	40.95	38.66	40.58	42.63	40.17	46.84	39.75	50.73	39.45	54.97		
		1150	46.01	19.92	45.76	21.82	45.51	23.71	45.31	28.12	45.01	32.74	44.82	37.34	44.62	42.04	44.23	46.64	44.75	50.97	43.44	55.07	43.18	59.76		
		1230	49.13	29.91	48.93	24.16	48.72	26.42	48.42	31.33	48.23	36.22	48.11	41.23	47.71	46.02	47.41	50.72	47.01	55.52	46.82	59.81	46.62	64.81		
		1310	52.21	24.32	52.01	26.76	51.81	29.23	51.51	34.21	51.32	39.62	51.13	44.81	50.92	50.11	50.62	55.02	50.42	59.91	50.13	64.52	49.81	69.72		
		1390	55.33	26.61	54.43	29.22	54.73	31.82	54.63	37.41	54.41	42.92	54.31	48.53	54.12	54.22	53.93	59.21	53.61	64.42	53.42	69.11	53.22	74.62		
1400	58.81	28.92	58.61	31.58	58.41	34.23	58.21	40.41	58.03	46.52	57.82	58.33	57.71	58.11	53.51	63.62	57.36	68.92	57.22	74.22	57.14	80.12				
DSR250	250A	990	63.60	15.50	63.40	21.20	63.10	28.80	62.90	35.80	62.70	41.80	62.50	48.60	62.20	55.30	62.10	61.80	66.70	61.60	73.30	61.40	76.70			
		1170	75.00	19.10	74.70	25.80	74.30	33.90	74.10	42.20	73.60	49.10	73.10	56.90	72.70	64.60	72.30	72.50	72.01	77.80	71.70	85.30	71.30	89.20		
		1250	80.30	19.60	80.00	26.80	79.60	36.30	79.20	45.20	78.80	52.60	78.50	61.10	78.20	69.50	72.90	78.10	77.40	83.60	77.10	91.70	76.80	96.10		
		1360	90.40	21.60	90.00	29.60	88.70	40.50	88.50	50.40	88.30	58.90	88.10	68.50	87.80	78.10	82.50	87.60	87.20	94.20	86.90	103.40	86.60	108.30		
1480	97.10	23.20	96.50	31.50	96.50	44.10	96.20	54.80	96.00	64.10	95.80	74.50	95.50	84.90	95.20	95.80	95.10	102.60	94.50	112.50	94.40	117.30				
DSR300	300A	990	89.30	21.90	89.21	30.10	88.90	32.10	88.70	46.10	88.50	55.30	88.30	64.30	88.10	73.40	87.90	73.20	67.60	77.10	67.40	94.30	67.10	108.80		
		1170	105.80	25.00	105.40	34.60	105.10	43.70	104.70	54.40	104.30	65.20	104.10	75.90	103.80	86.40	103.50	90.60	103.20	101.10	102.90	110.10	102.70	128.40		
		1250	112.90	29.40	112.50	40.30	112.20	46.70	112.10	58.20	111.80	69.80	111.60	81.30	111.40	92.80	111.20	97.80	110.90	108.80	110.50	119.60	110.20	138.20		
		1360	125.80	30.20	125.40	41.50	125.10	52.10	124.80	64.50	124.60	77.50	124.40	90.70	124.20	103.40	124.10	109.10	123.80	121.30	123.60	133.50	123.40	154.20		
		1480	136.70	31.60	136.30	43.80	135.90	56.20	135.70	70.60	135.60	84.30	135.30	98.60	135.10	112.50	134.90	118.70	134.70	132.10	134.50	145.30	134.30	167.80		
DSR350	350A	990	129.40	24.40	127.40	36.60	125.40	48.80	123.80	61.00	122.20	75.20	120.80	85.36	119.40	97.50	118.10	109.70	116.80	121.90	114.35	134.10	111.90	146.30		
		1170	154.70	28.80	152.65	43.20	150.60	57.60	149.00	72.05	147.40	86.50	146.00	100.90	144.60	115.30	143.35	129.70	142.10	144.10	139.65	158.50	137.20	172.90		
		1250	165.70	30.80	163.75	46.20	161.80	61.60	160.20	77.00	158.60	92.40	157.20	107.80	155.80	123.20	154.55	138.55	153.30	153.90	150.90	169.30	148.50	184.70		
		1360	181.30	33.50	179.30	50.25	177.30	67.00	175.70	83.75	174.10	100.50	172.70	117.25	171.30	134.00	170.00	150.75	168.70	167.50	166.30	184.25	163.90	201.00		
1480	198.10	36																								

PERFORMANCE TABLE (BELT & PULLEY)

Pressure Performance Table

Qs = Inlet air flow (m3/min)

La = Blower shaft power (Kw)



Model	Bore	Mmaq	Pressure															
			6500		7000		7500		8000		8500		9000		9500		10.000	
			KPA		63.7		68.6		73.5		78.4		83.3		88.2		93.1	
Rpm		Qs	La	Qs	La	Qs	La	Qs	La	Qs	La	Qs	La	Qs	La	Qs	La	
DSR 50	50A	1240	0.78	2.01	0.73	2.10	0.69	2.49	0.62	2.79	0.61	3.37	0.56	3.95	0.50	4.17	0.45	4.41
		1350	0.95	2.23	0.85	2.28	0.86	2.76	0.79	3.01	0.78	3.40	0.76	3.92	0.73	4.37	0.69	4.81
		1450	1.06	2.35	1.00	2.42	0.97	2.90	0.93	3.21	0.90	3.68	0.87	4.05	0.83	4.60	0.79	5.07
		1530	1.22	2.55	1.18	2.52	1.16	3.18	1.13	3.56	1.08	3.88	1.03	4.20	0.90	4.61	0.85	5.10
		1640	1.38	2.75	1.35	2.63	1.32	3.32	1.29	3.75	1.24	4.27	1.18	4.43	1.13	4.80	1.06	5.20
		1730	1.50	2.93	1.46	2.92	1.42	3.54	1.39	3.91	1.31	4.38	1.26	4.70	1.22	5.12	1.14	5.50
DSR 65	65A	1240	1.13	2.89	1.10	2.88	1.03	3.49	0.98	4.01	0.89	4.20	0.88	4.56	0.83	4.92	0.78	5.28
		1360	1.39	3.08	1.31	3.05	1.28	3.76	1.19	4.12	1.17	4.40	1.15	5.02	1.12	5.40	1.08	5.87
		1450	1.60	3.35	1.51	3.42	1.47	4.05	1.40	4.21	1.41	4.85	1.38	5.23	1.35	5.51	1.31	5.96
		1530	1.74	3.50	1.70	3.60	1.64	4.14	1.57	4.39	1.53	5.10	1.48	5.40	1.42	5.62	1.35	6.01
		1640	1.98	3.74	1.90	3.94	1.86	4.42	1.79	4.54	1.75	5.25	1.70	5.40	1.65	5.78	1.60	6.10
DSR 80	80A	1740	2.18	4.13	2.10	4.27	2.06	5.05	2.00	4.65	1.92	5.80	1.84	6.10	1.75	6.35	1.70	6.50
		1140	2.27	4.09	2.25	4.22	2.19	4.83	2.14	4.73	2.01	5.61	1.96	5.97	1.89	6.33	1.82	6.69
		1230	2.52	4.49	2.49	4.71	2.37	5.30	2.35	5.32	2.25	6.10	2.19	5.45	2.12	6.81	2.06	7.17
		1300	2.77	4.82	2.71	5.11	2.61	5.69	2.55	5.85	2.48	6.40	2.40	6.71	2.35	7.26	2.29	7.66
		1360	2.95	5.18	2.87	5.27	2.77	5.99	2.73	5.93	2.62	5.80	2.57	7.21	2.49	7.53	2.46	7.93
		1460	3.07	5.67	3.22	5.76	2.92	6.44	3.10	6.46	2.78	7.03	2.65	7.38	2.60	7.90	2.55	8.10
		1560	3.44	6.17	3.38	6.25	3.30	6.97	3.24	7.05	3.18	7.40	3.15	7.70	3.10	8.13	3.07	8.35
DSR 100	100A	1650	3.73	6.55	3.68	6.72	3.62	7.45	3.55	7.63	3.40	8.00	3.32	8.20	3.27	8.40	3.21	8.70
		1730	4.01	6.94	3.96	7.05	3.88	7.84	3.79	7.95	3.70	8.40	3.65	8.71	3.61	8.98	3.52	9.10
		1060	3.17	6.36	3.07	6.71	3.01	7.51	2.87	7.62	2.87	8.53	2.79	8.89	2.72	9.25	2.65	9.61
		1140	3.65	6.90	3.59	7.32	3.51	8.15	3.46	8.35	3.40	8.90	3.36	9.10	3.54	9.50	3.48	9.86
		1220	4.06	7.52	3.93	8.02	3.90	8.88	3.82	9.12	3.75	10.10	3.68	10.40	3.61	11.32	3.55	11.96
		1310	4.43	8.15	4.36	8.56	4.26	9.62	4.18	9.65	4.10	10.82	4.03	11.50	3.90	11.71	3.82	12.10
		1460	5.28	9.23	5.19	9.37	5.10	10.44	5.00	10.06	4.78	11.32	4.61	11.85	4.48	12.30	4.30	12.75
		1560	5.70	9.75	5.63	10.35	5.55	11.12	5.45	11.75	5.38	11.98	5.32	12.21	5.24	12.80	5.15	13.20
DSR 125	125A	1680	6.44	10.77	6.37	11.50	6.25	12.21	6.20	12.61	6.00	12.90	5.85	13.20	5.71	13.67	5.49	14.10
		1780	6.95	11.52	6.88	11.98	6.83	13.07	6.70	13.45	6.55	13.92	6.38	14.10	6.10	14.52	5.91	14.88
		980	5.24	8.92	5.19	9.34	5.08	10.98	5.01	10.65	4.85	13.20	4.78	14.10	4.71	15.30	4.64	16.40
		1050	5.54	9.71	5.42	10.15	5.32	11.98	5.27	11.60	5.11	14.08	5.01	15.11	4.92	16.01	4.80	16.71
		1200	6.83	11.05	6.77	11.84	6.66	12.56	6.45	13.44	6.21	14.23	6.06	15.38	5.80	16.26	5.55	16.91
		1300	7.55	12.12	7.45	13.15	7.38	13.92	7.26	14.93	7.01	15.66	6.53	16.43	6.56	17.01	6.22	17.85
		1390	8.14	13.14	8.03	13.95	7.92	14.91	7.85	15.72	7.61	16.20	7.32	17.15	7.06	17.68	6.71	18.03
		1450	8.50	13.73	8.42	14.62	8.33	15.62	8.24	16.53	8.08	17.10	7.90	17.72	7.73	18.21	7.46	19.21
		1530	9.05	14.63	8.97	15.60	8.87	16.63	8.80	17.52	8.61	18.01	8.48	18.71	8.21	19.40	8.00	21.10
1630	9.75	15.65	9.68	16.81	9.55	17.82	9.50	19.01	9.31	19.60	9.15	20.30	8.93	20.98	8.80	21.60		
1750	10.55	16.94	10.46	18.18	9.55	19.14	10.29	20.53	10.05	21.00	9.87	21.80	9.80	22.35	9.62	23.10		

● Please contact us for outline dimension and installation drawing, performance curve and noise curve.

PERFORMANCE TABLE (BELT & PULLEY)

Pressure Performance Table

Qs = Inlet air flow (m³/min)

La = Blower shaft power (Kw)

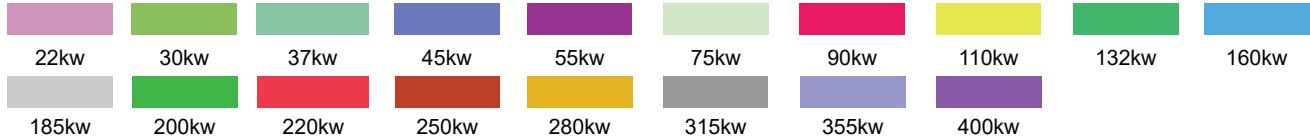

Model	Bore	Pressure																	
		Mmaq	6500		7000		7500		8000		8500		9000		9500		10.000		
		KPA	63.7		68.6		73.5		78.4		83.3		88.2		93.1		98.0		
		Rpm	Qs	La	Qs	La	Qs	La	Qs	La	Qs	La	Qs	La	Qs	La	Qs	La	
DSR 150	150 A	810	10.26	17.16	10.11	18.00	10.06	20.73	9.84	20.40	9.80	24.38	9.75	25.98	9.64	27.28	9.53	28.58	
		860	11.16	17.77	11.00	19.42	10.85	20.87	10.37	22.03	10.62	25.67	10.51	26.97	10.40	28.27	10.29	29.57	
		970	13.12	21.45	12.95	22.15	12.86	24.34	12.67	24.91	12.51	26.50	12.23	30.30	11.97	33.40	11.65	37.21	
		1110	15.55	25.07	15.45	26.02	15.33	28.45	15.20	29.21	15.00	32.60	14.78	35.00	14.42	38.60	14.01	42.30	
		1180	16.88	26.34	16.76	27.35	16.55	30.15	16.40	30.65	16.27	33.20	16.10	36.30	15.89	41.10	15.71	44.23	
		1240	17.92	27.73	17.82	29.20	17.66	31.43	17.62	32.60	17.21	36.21	17.10	39.38	16.80	44.45	16.63	47.78	
		1400	20.76	33.34	20.68	33.60	20.45	37.97	20.30	37.50	20.11	43.00	19.87	46.10	19.63	49.80	19.48	52.00	
		1450	21.70	33.95	21.65	35.65	21.51	38.54	21.42	39.80	21.30	44.80	21.11	47.10	20.90	50.90	20.71	54.00	
		1520	22.92	34.57	22.75	37.70	21.69	39.12	21.50	42.10	21.12	46.80	21.01	49.30	20.70	53.20	20.32	58.10	
		1620	24.12	40.07	24.05	41.71	23.85	45.83	23.70	46.60	23.50	51.10	23.31	54.00	23.13	57.80	22.90	50.10	
DSR 200	200 A	810	27.26	47.34	26.93	43.35	26.62	48.52	26.33	51.73	26.12	55.20	25.87	58.20	25.61	61.40	25.34	64.61	
		900	31.45	47.64	31.14	51.23	30.35	54.52	30.54	57.85	30.21	60.80	29.90	64.01	29.58	67.20	29.26	70.41	
		980	35.05	53.03	34.72	56.75	34.38	60.55	34.05	64.23	33.80	66.80	33.62	69.10	33.36	74.87	33.01	80.09	
		1070	39.35	58.83	39.13	63.73	38.92	67.37	38.75	70.44	38.58	74.01	38.37	77.20	38.11	80.50	37.90	84.20	
		1150	43.03	64.33	42.74	68.63	42.45	73.34	42.25	77.66	42.03	80.10	41.81	84.20	41.63	87.50	41.45	90.70	
		1230	46.41	69.32	46.21	74.22	46.02	78.81	45.83	83.52	45.60	86.10	45.42	89.10	45.20	92.30	45.02	96.10	
		1310	49.72	74.81	49.53	79.71	49.32	84.72	49.11	89.76	48.90	92.10	48.68	95.30	48.41	99.20	48.25	105.10	
		1390	53.03	79.65	52.82	84.91	52.71	90.24	52.52	95.55	52.18	98.70	52.10	103.20	51.90	107.20	51.72	112.10	
		1480	56.92	85.61	56.82	91.32	56.71	96.72	56.53	102.40	56.21	106.30	56.10	110.10	55.75	115.20	55.40	120.00	
DSR 250	250 A	990	61.80	83.20	61.20	88.90	60.40	93.60	59.80	99.70	59.20	112.10	58.80	120.10	58.30	129.60	58.01	137.20	
		1170	71.20	96.10	69.60	101.50	69.40	108.50	59.20	115.10	58.60	126.20	58.20	134.40	67.70	140.10	67.10	152.10	
		1250	76.40	103.50	76.10	110.80	75.60	118.20	75.10	125.20	74.50	142.20	74.10	149.10	73.40	155.20	73.20	165.20	
		1360	86.50	112.50	86.20	125.60	85.70	133.90	85.40	142.40	85.10	154.10	84.70	165.20	84.30	177.10	84.20	183.10	
		1480	93.70	126.90	93.40	136.20	93.20	145.60	92.60	154.30	92.20	170.10	91.80	184.10	91.50	192.10	91.20	205.20	
DSR 300	300 A	990	86.90	114.70	86.70	123.60	86.40	127.10	86.10	135.10	85.50	150.10	85.10	165.10	84.60	172.30	83.80	181.50	
		1170	102.50	135.30	102.30	145.30	102.10	150.10	101.80	159.80	101.50	170.50	101.10	182.10	100.80	200.00	100.50	227.20	
		1250	110.40	145.40	110.20	155.80	110.00	161.70	109.80	171.40	109.30	187.10	108.90	203.10	108.60	220.10	108.30	234.10	
		1360	123.20	162.60	123.10	176.60	122.70	180.40	122.50	192.30	122.20	206.10	122.10	217.50	121.70	232.10	121.50	254.50	
		1480	134.40	177.80	134.20	190.60	133.80	196.70	133.50	209.90	132.80	213.10	132.00	235.10	131.50	250.10	130.8	270.1	
DSR 350	350 A	990	110.65	158.50	109.40	170.70	108.15	181.80	106.90	195.10	105.70	207.30	104.50	219.50	103.35	231.70	102.20	243.90	
		1170	135.95	187.30	134.70	201.70	133.50	216.15	132.30	230.60	131.15	245.00	130.00	259.40	128.85	273.80	127.70	288.20	
		1250	147.25	200.00	146.00	215.50	144.80	230.90	143.60	246.30	142.45	261.70	141.30	277.10	140.15	292.50	139.00	307.90	
		1360	162.65	217.75	161.40	234.50	160.25	251.25	159.10	268.00	157.95	284.75	156.80	301.50	155.65	318.00	154.50	335.00	
		1480	179.55	236.95	179.30	254.50	177.10	273.40	175.90	291.60	174.75	309.85	173.60	328.10	172.50	346.30	171.40	364.00	

● Please contact us for outline dimension and installation drawing, performance curve and noise curve.

NOISE LEVEL

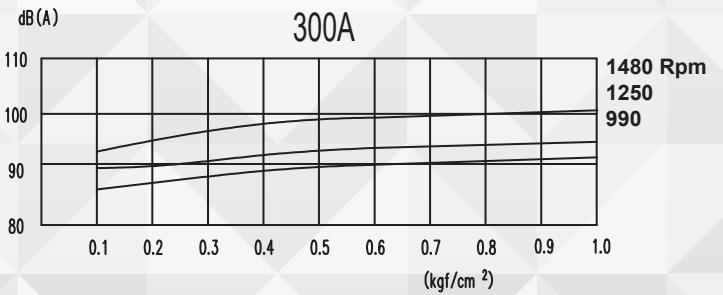
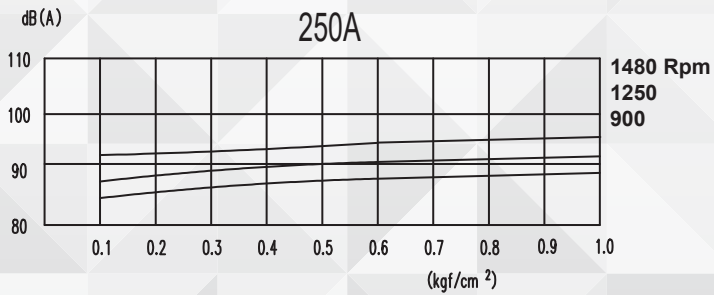
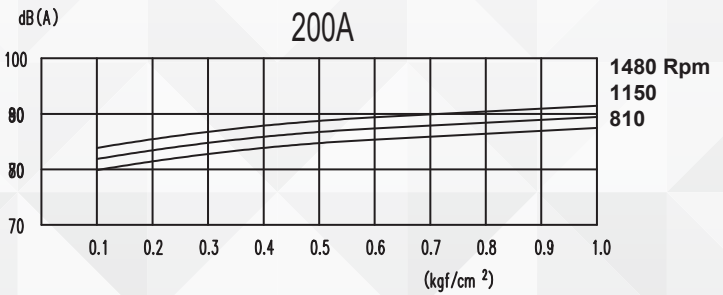
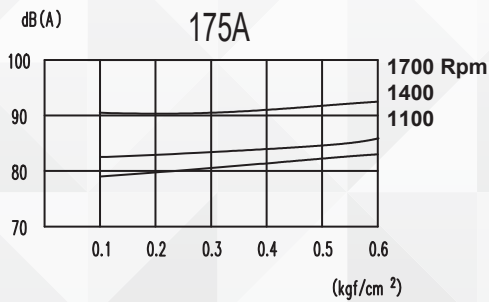
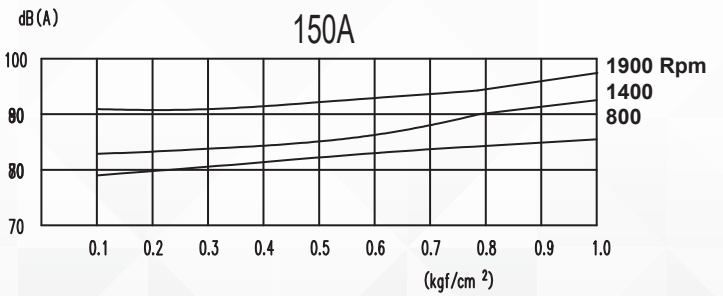
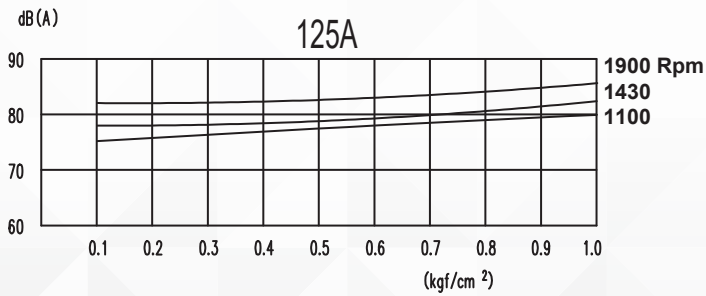
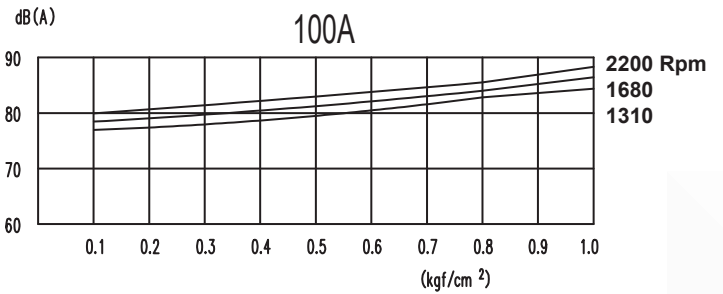
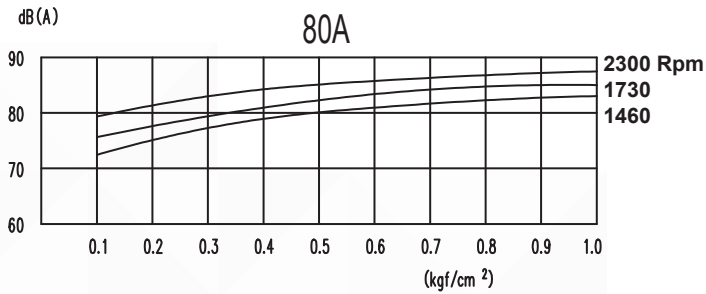
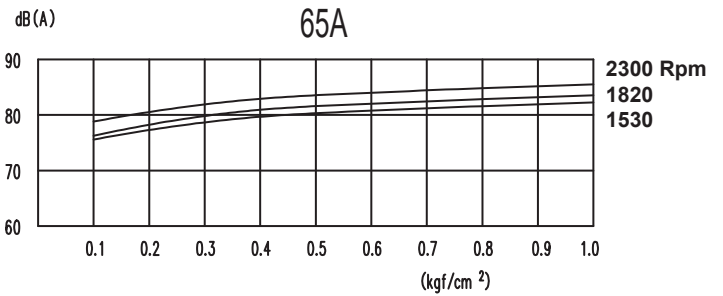
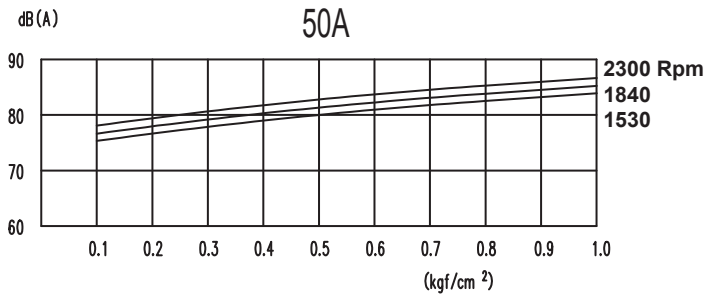

REFERENCE PIPING INSTALLATION DRAWING

● PIPELINE INSTALLATION DIAGRAM

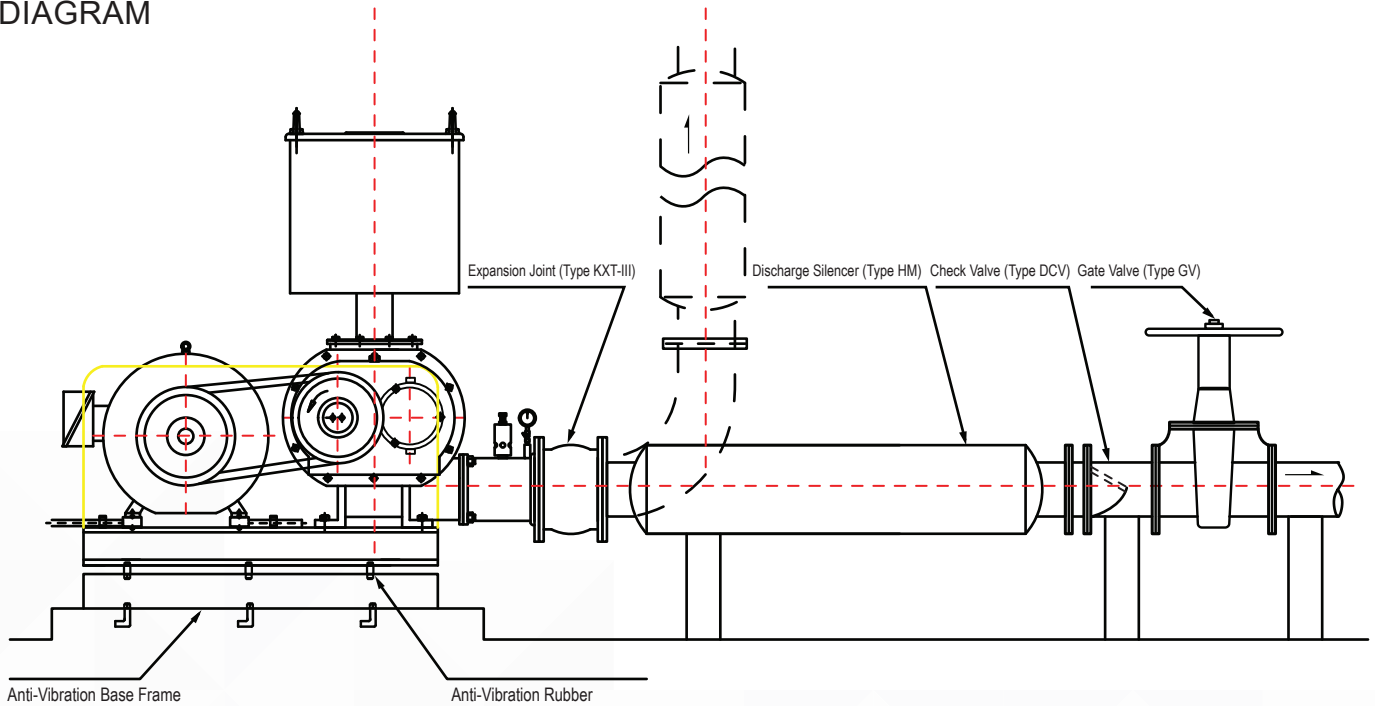

Note : Make Sure that the piping of check valve type DCV is Horizontal

● BELT JOINT INSTALLATION DIAGRAM

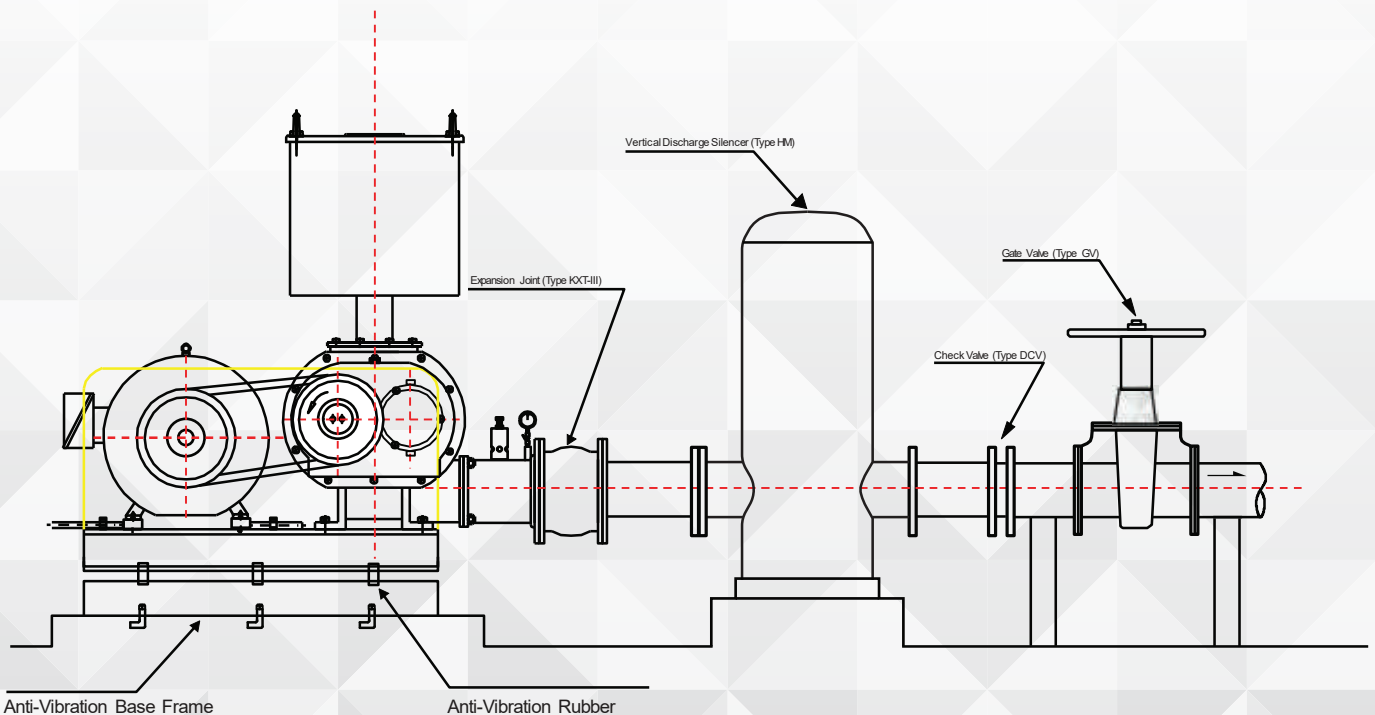

Note : Make Sure that the piping of check valve type DCV is Horizontal

OUTLINE DIMENSIONS

● DSR BELT TRANSMISSION EXTERNAL DIMENSIONS

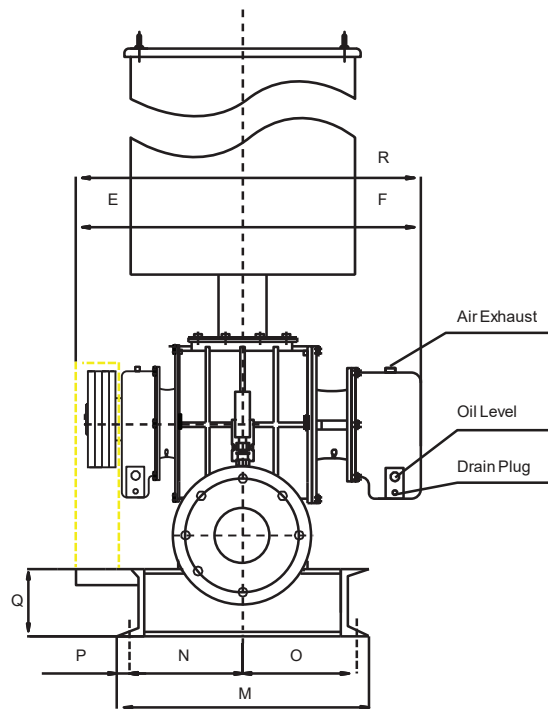

Model	Bore	A	B	C	D	E	F	G	H	J	K
DSR-50	50A	270	170	120	790	200	190	560	410	75	-
DSR-65	65A	270	170	130	900	220	210	600	450	75	-
DSR-80	80A	305	195	150	1170	220	220	650	500	75	-
DSR-100	100A	305	195	160	1240	280	260	730	580	75	-
DSR-125	125A	345	200	190	1410	290	270	860	700	80	350
DSR-150	150A	390	220	215	1680	380	400	960	750	80	400
DSR-175	175A	390	220	215	1680	480	500	1050	750	125	400
DSR-200	200A	490	275	260	2060	500	520	1280	1000	140	500
DSR-250	250A	640	280	380	2660	690	590	1900	1500	200	750
DSR-300	300A	695	335	395	2780	780	700	1900	1500	200	750
DSR-350	350A	695	335	395	2880	780	765	1900	1500	200	750

Model	Bore	L	M	N	O	P	Q	n	R	S	Weight (Kg)
DSR-50	50A	-	300	115	155	15	80	4	390	708	85
DSR-65	65A	-	340	125	175	15	80	4	430	820	98
DSR-80	80A	-	360	125	205	15	80	4	440	895	148
DSR-100	100A	-	470	150	265	15	80	4	540	975	190
DSR-125	125A	350	470	170	270	15	100	6	560	1110	280
DSR-150	150A	350	590	250	300	20	100	6	780	12030	470
DSR-175	150A	350	770	350	380	20	100	6	980	1320	600
DSR-200	200A	500	755	355	380	20	120	6	1020	1605	820
DSR-250	250A	750	950	495	405	25	160	6	1280	2230	1700
DSR-300	300A	750	950	585	415	25	160	6	1480	2285	2100
DSR-350	350A	750	1050	570	430	25	160	6	1530	2285	2350

High Pressure (63.7kpa-98kpa) blower

ACCESORIES

- INLET SILENCER (HF)

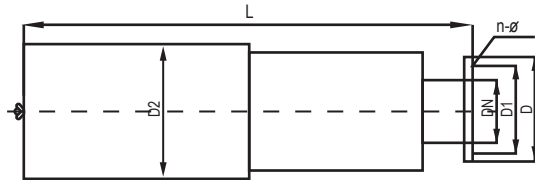

Model	D	D	D	D	L	N-D	(Kg)
DSR-50	50	58	110	170	440		5
DSR-65	65	130	160	170	550	4-Ø 14	7
DSR-80	80	133	165	250	740	4-Ø 14	16
DSR-100	100	147	185	270	800	4-Ø 14	20
DSR-125	125	175	210	270	900	4-Ø 14	20
DSR-150	150	225	250	350	1100	8-Ø 18	35
DSR-175	150	225	250	350	1100	8-Ø 18	60
DSR-200	200	280	310	120	1360	8-Ø 18	60
DSR-250	250	350	380	560	1650	12-Ø 18	120
DSR-300	300	400	450	600	1750	12-Ø 18	140
DSR-350	350	460	505	650	1850	12-Ø 18	180

- OUTLET SILENCER (HM)

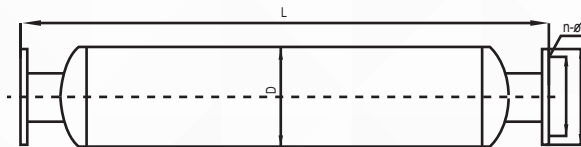

Model	BORE	A	B	I	D	E	n-H	(Kg)
DSR-50	50	125	165	600	140	125	4-Ø 19	10
DSR-65	65	145	185	700	165	145	4-Ø 19	14
DSR-80	80	160	200	900	190	160	8-Ø 19	25
DSR-100	100	180	220	1200	217	180	8-Ø 19	33
DSR-125	125	210	250	1400	261	210	8-Ø 19	43
DSR-150	150	240	285	1600	286	240	8-Ø 23	57
DSR-175	150	245	285	1600	286	240	8-Ø 23	57
DSR-200	200	295	340	1800	320	295	8-Ø 23	98
DSR-250	250	350	395	2000	406	350	12-Ø 22	130
DSR-300	300	400	445	2000	500	400	12-Ø 22	160
DSR-350	350	460	560	2000	598	420	16-Ø 22	220

- VERTICAL OUTLET SILENCER (HL)

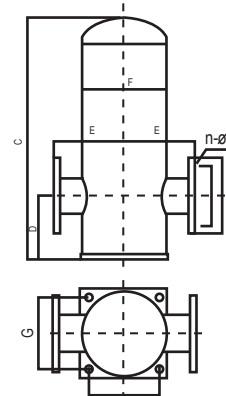

Model		A	B	C	D	E	F	G	n-H	(Kg)
DSR-50	50	125	165	450	130	140	165	140	4-Ø 19	14
DSR-65	65	145	185	500	140	170	190	170	4-Ø 19	16
DSR-80	80	160	200	610	150	190	217	190	8-Ø 19	25
DSR-100	100	180	220	680	160	220	261	230	8-Ø 19	33
DSR-125	125	210	210	250	820	200	240	286	8-Ø 19	43
DSR-150	150	240	285	940	220	290	320	300	8-Ø 23	57
DSR-175	150	240	285	940	220	290	320	300	8-Ø 23	57
DSR-200	200	295	340	1060	260	320	438	370	8-Ø 23	98
DSR-250	250	350	395	1200	300	360	554	480	12-Ø 22	142
DSR-300	300	400	445	1500	450	410	604	510	12-Ø 22	178
DSR-350	350	460	505	1600	480	470	654	560	16-Ø 22	220

- CHECK VALVE (DCV)

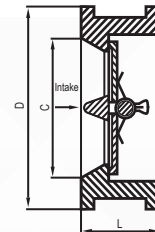

Model	Nominal Diameter (mm)	(inch)	L	d	D	(Kg)
DSR-50	50	2	45	22	105	1.1
DSR-65	65	2.5	50	32	130	1.8
DSR-80	80	3	68	48	140	2
DSR-100	100	4	68	58	160	2.8
DSR-125	125	5	70	80	188	4
DSR-150	150	6	76	102	218	5.4
DSR-175	150	8	76	148	270	8.4
DSR-200	200	8	90	148	270	8.4
DSR-250	250	10	114	187	325	12.8
DSR-300	300	12	114	220	380	21.4
DSR-350	350	14	114	270	436	33

- CHECK VALVE (DCV)

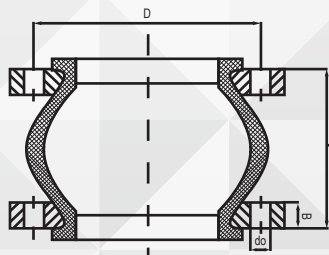

Nominal (mm)	Diameter (inch)	L (mm)	B (mm)	(Bore no.)	do (mm)	D (mm)
50	(2)	105	18	4	17.5	125
65	(2 ½)	115	20	4	17.5	145
80	(3)	135	20	8	17.5	160
100	(4)	150	22	8	17.5	160
125	(5)	165	24	8	17.5	210
150	(6)	180	24	8	22	240
200	(8)	190	24	8	22	295
250	(10)	230	28	12	22	350
300	(12)	245	28	12	22	400
350	(14)	255	28	16	22	460
400	(16)	255	30	16	26	565
450	(18)	255	30	20	26	565
500	(20)	255	32	20	26	620
600	(24)	260	35	20	30	725